

Hybrid photon model bridges classical and quantum optics

ChandraSekhar Roychoudhuri

Physics Department, University of Connecticut, Storrs, CT 06269

Chandra.Roychoudhuri@uconn.edu

Paper download: <http://www.natureoflight.org/CP/>

What is a photon?

Then, the photoelectric equation should contain a dipolar polarizability term.



“A photon is what a photodetector detects.”

Nobel Laureate
Roy J. Glauber,

Observations:

- 1. Huygens-Fresnel Diffraction integral (since 1817) and Maxwell's electromagnetism equations (since 1867) have been guiding the sustained growth of optical science and engineering till today. Optical engineers do not propagate “indivisible photons”.
Then, Classical Optics has been modeling nature correctly for two hundred years.
- 2. Schrodinger's and Heisenberg's mathematical formalisms (since 1925) have been successfully modeling atoms and molecules, specifically, light emission and absorption.
Then, Quantum Optics has also been modeling nature for 92 years.

How to bridge the gap between these two correct formalisms?

Postulate: *A photon is a transient entity, which facilitates the conversion of energy released by quantized materials into a classical wave packet.*

- Classical Optics models accept time-finite wave packets as a physical solutions.
- Quantum Optics thrives on quantized energy release and absorption.
- **Then, what are the issues to justify the above postulate?**

Accommodating quantized emission

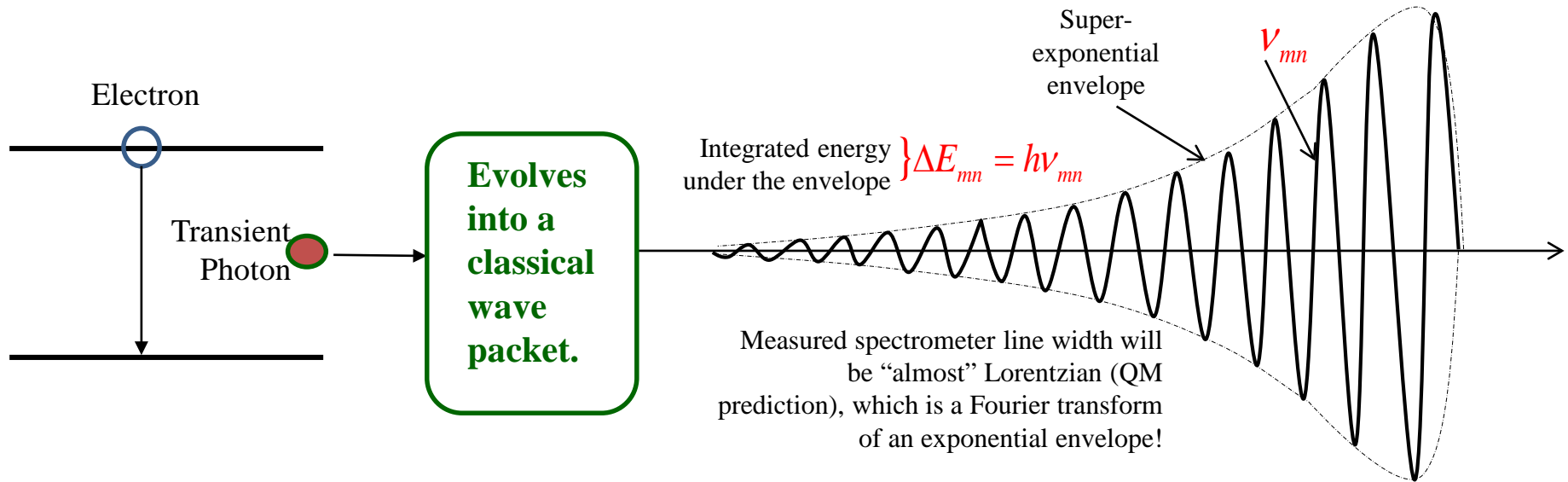

- 1. Quantized energy is accommodated as the energy under the envelope.
- 2. Quantum frequency is preserved as the carrier frequency.
- 3. Semi-exponential envelope is justified based upon measured spectrometer fringe shape being Lorentzian for spontaneous emissions.
- 4. The Fourier transform of the semi-exponential wave packet closely resembles a Lorentzian spectral envelope [1]; which is also the prediction of classical and quantum physics and validated by numerous experiments.

[1] C. Roychoudhuri, See Ch.5 for theory of pulsed light spectrometry in “Causal Physics: Photon Modell by Non-Interaction of Waves; CRC, 20014.

Accommodating quantized absorption from wave packets

Un-excited atoms and molecules are potentially discrete “quantum cups”

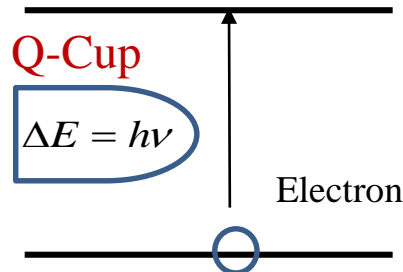
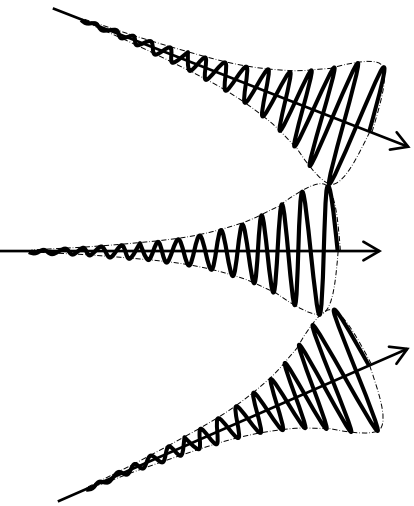

Diffractively spreading multiple wave packets fill up the Quantum Cup to help the upward transition.

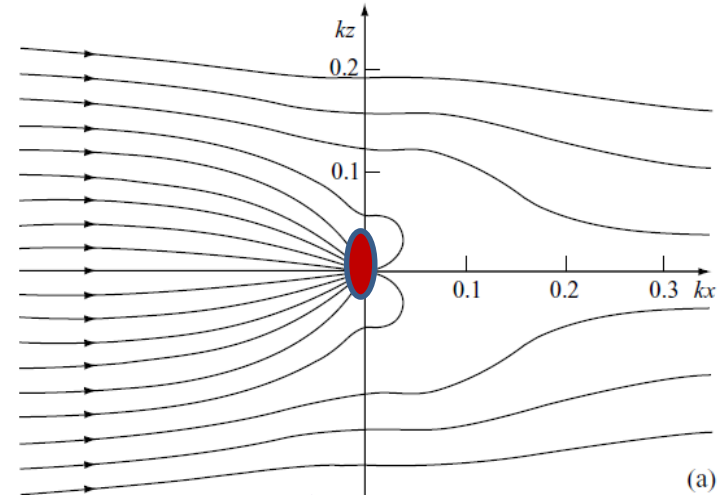

See p.53 in *Introduction to Quantum Optics*, by H. Paul, Cambridge U. Press, 2004..

- Once stimulated by EM waves, the dipole facilitates the convergence of EM field energy. There is a **push** (by the field) and **pull** (by the dipole) during the interaction. Energy is collected out of a very large volume compared to the atomic volume of \sim one cubic Angstrom.
- A propagating electromagnetic wave packet cannot deliver all its energy instantly; or at a rate faster than its finite velocity c or c/n . The “**Push-Pull**” interaction still assures energy absorption in the Femto second domain

Experimental validation of atom's large "Quantum Cup" Suction volume!

A propagating electromagnetic wave packet cannot deliver all its energy instantly; or at a rate faster than its finite velocity c or c/n .

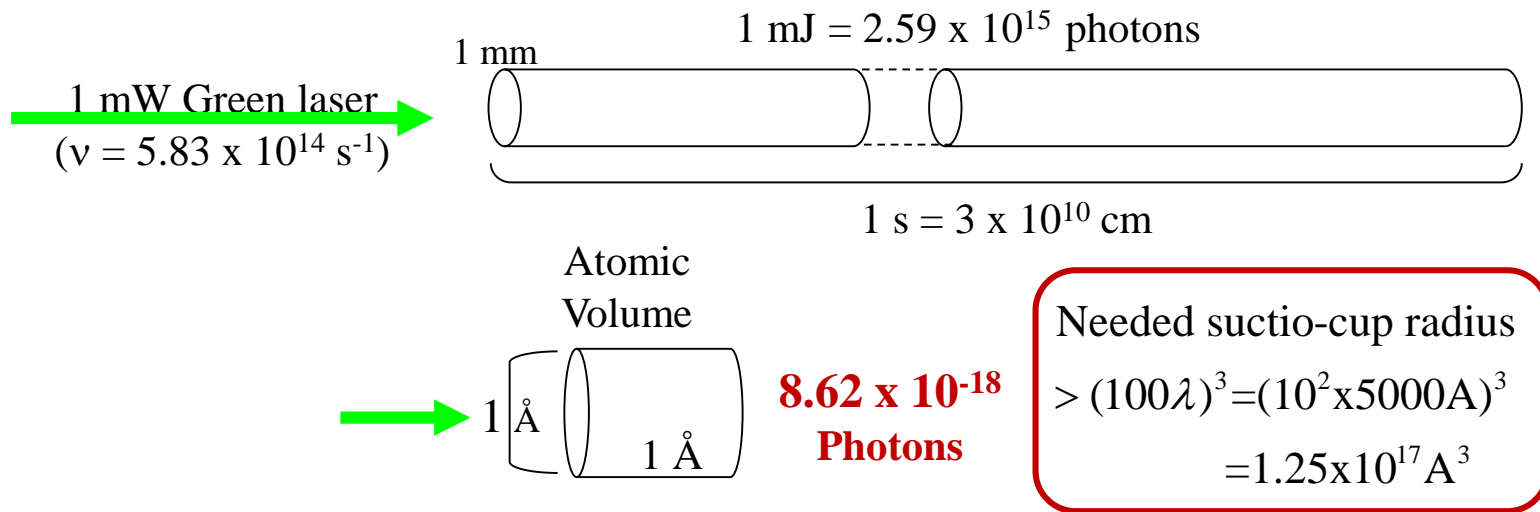

- A remarkably low flux of EM field energy passes through an atomic volume! Some very complex process lies behind the delivery of ΔE amount of energy for the transfer of a photo electron from one state to another, which QM has not succeeded in explaining, or modeling!
- We have done a similar experiment with low-pressure Rb-atoms at resonance absorption using 1mW beam [2].

[2] D. Lee & C. Roychoudhuri, *Optics Express*, Vol. 11, No. 8, p.944 (2003).

Is “indivisible light quanta” the right postulate?

Einstein could have developed quantum mechanics had he recognize that *all electrons are bound quantum mechanically in materials*. He could have also recognized Non-Interaction of Waves (NIW) [1].

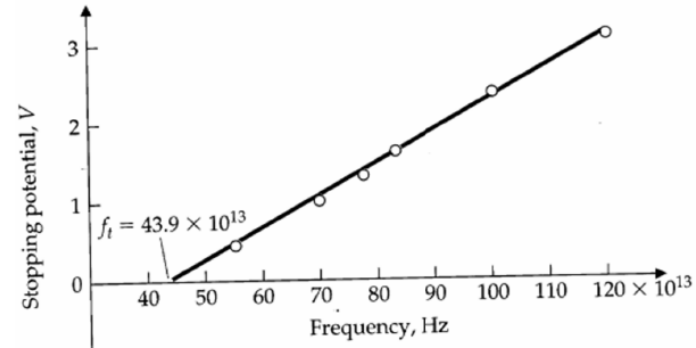
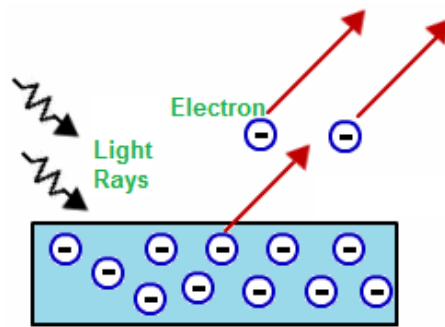
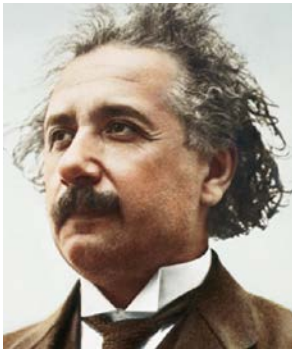

Einstein did say that in spite of 50 years’ of brooding, he was still confused about what “indivisible light quanta” are.

$$\langle |\psi_{res.}|^2 \rangle = \langle \left| \sum_q \chi(\nu_q) E(\nu_q) \right|^2 \rangle \propto \langle h\nu_q \rangle = \langle \phi_{work\ fn.} + (1/2)m v_{el.}^2 \rangle$$

Ensemble average of multiple dipolar amplitude stimulations of the same quantum detector & quadratic energy transfer

Einstein’s original eq. under ensemble average, equating only the energy transfer

Photoelectric equation incorporating the *semi-classical model*

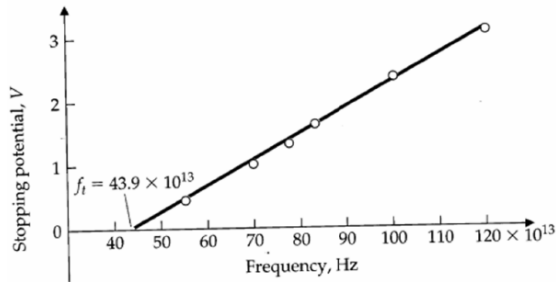

Millikan's plot of photoelectric effect

Einstein's heuristic eq. wrongly assigns the "quantumness", he discovered, to the EM waves, rather than to bound electrons:

$$h\nu = \phi_{work\ fn.} + (1/2)mv_{el.}^2$$

Recovering Einstein's Eq.

See slide #20 in, "Urgency of evolution process congruent thinking in physics"; Proc. SPIE Vol. 9570, paper #7 (2015).

Elementary stimulation of the electron holding dipole complex:

$$\psi = \chi(\nu_q)E(\nu_q)$$

There are always multiple wave packets:

$$\psi_{res.} = \sum_q \chi(\nu_q)E(\nu_q)$$

Release of each bound electron requires a quadratic energy absorption process (filling the "Quantum Cup":

$$|\psi_{res.}|^2 = \left| \sum_q \chi(\nu_q)E(\nu_q) \right|^2 \Leftarrow [h\nu_q]_{QM\ Cup}$$

Only ensemble average can generate a data-curve:

$$\begin{aligned} \langle |\psi_{res.}|^2 \rangle &= \left\langle \left| \sum_q \chi(\nu_q)E(\nu_q) \right|^2 \right\rangle = \langle h\nu_q \rangle_{Many\ QM\ Cups} \\ &= \left\langle \phi_{work\ fn.} + (1/2)mv_{el.}^2 \right\rangle \end{aligned}$$

If we use a very narrow frequency radiation, the polarizability factor will be a constant & we can get the mistaken concept that wave amplitudes sum themselves even in the absence of interacting materials::

$$|\psi_{res.}|^2 = \left| \sum_q \chi(\nu_q)E(\nu_q) \right|^2 = \chi^2 \left| \sum_q E(\nu_q) \right|^2$$

Superposition Effect *can be a pure classical phenomenon.*

No quantization is required!

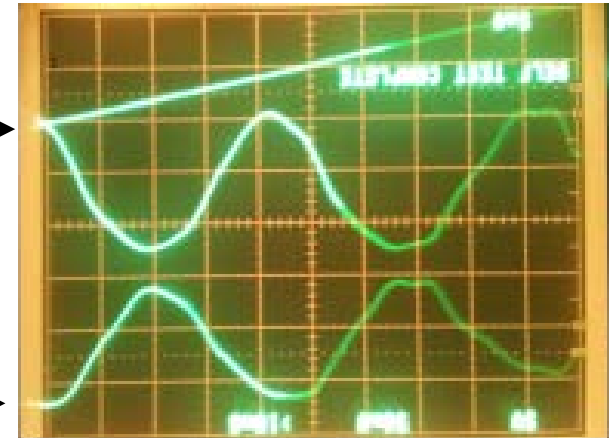
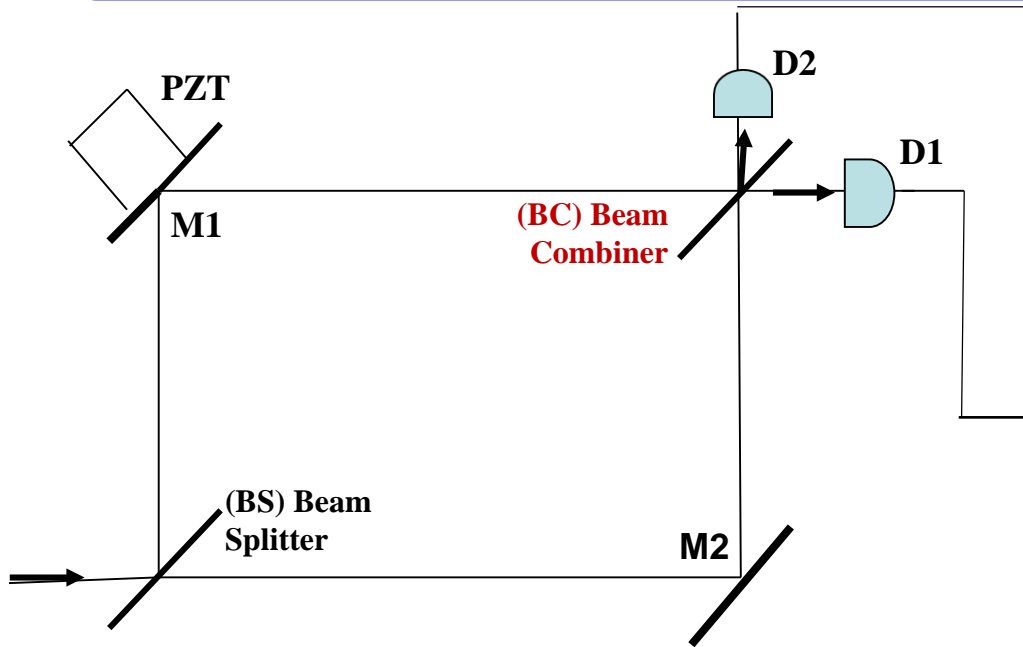

As M1 is scanned, all the energy of both the beams could go to either D1 or to D2, depending upon the phase conditions. The 50% BC effectively oscillates between being a 100% reflector or a 100% transmitter! What is the physics?

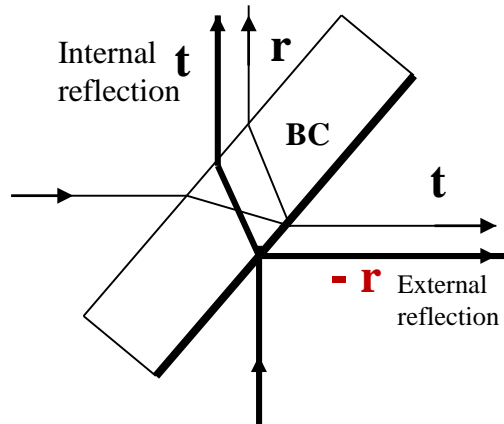

Collinear Poynting vectors on BC. Scanning fringe mode.

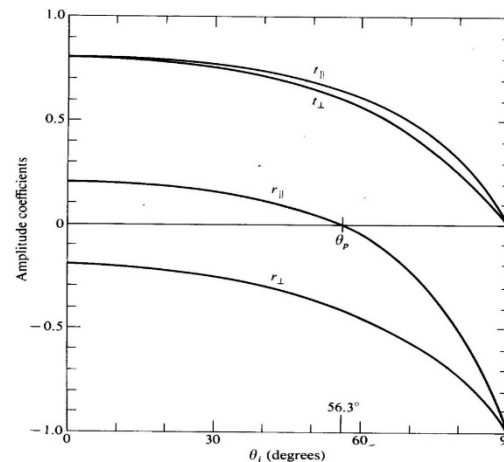

Note: “pi” phase shift between external and internal reflection.

From Hecht

Demonstration that the presence of two optical signal from the opposite sides of the beam combiner is essential to generate superposition effect.

Visually observable pure classical superposition effect generated by a beam combiner. No quantum detector used!

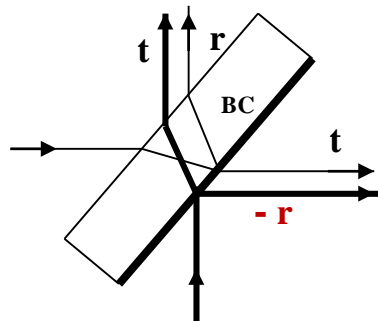
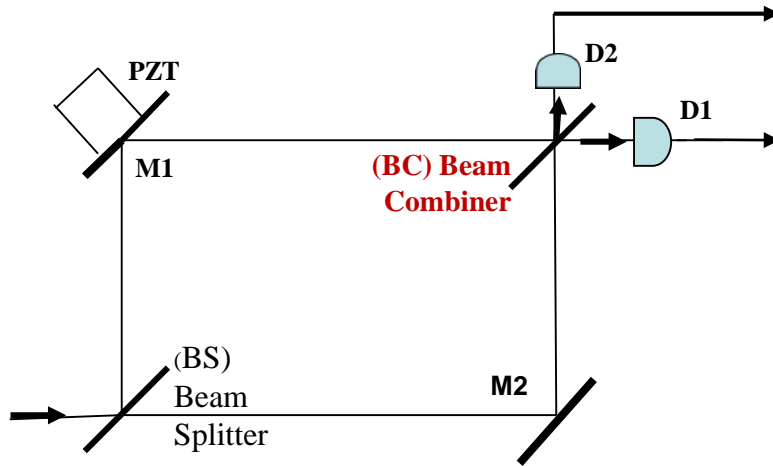

Collinear Poynting vectors on BC.
Scanning fringe mode.



The two light signals must stimulate the boundary-layer molecules simultaneously from the two opposite sides for the energy re-direction (Superposition Effect) to take place. Even if “indivisible single photon” existed; we would need two of them to incident simultaneously from the opposite sides of the beam combiner.

Values of the paper

Why “indivisible single photon interference” is a non-causal proposition?

- 1. The “Hybrid Photon” model eliminates the need for the ad hoc postulate, “wave-particle duality”. Interpretation of Quantum Mechanics becomes stronger and more realistic without this ad hoc postulate.
- 2. Superposition Effect can be purely classical or quantum mechanical, depending upon the situation. *Semi-classical model explains both situations.*
- 3. Mathematically, the linear superposition principle (**SP**) represents linear sum of two or more “amplitude-phase-entities” *stimulating* the boundary of a beam combiner or a quantum detector:

$$\psi_{res.} = \chi a_1 e^{i2\pi\nu t} + \chi a_2 e^{i2\pi\nu(t+\tau)}$$

SP is not directly observable. Besides, a single stable elementary particle cannot simultaneously carry multiple physical values for the same physical parameter.

- 4. The observable Superposition Effect is a non-linear quadratic process:

$$|\psi_{res.}|^2 = \chi^2 a_1^2 + \chi^2 a_2^2 + 2\chi^2 a_1 a_2 \cos 2\pi\nu\tau$$

Only light-matter interaction can execute this *quadratic interaction* step. So, an “indivisible photon”, by itself, cannot generate Superposition Effect. Further, *the energy is provided by both the beams (note the separate presence of a_1 & a_2)!*

What is a photon?

- ❖ *A photon is a transient entity, which facilitates the conversion of energy released by quantized materials into a classical wave packet.*
- ❖ *Quantum Mechanics becomes more realistic without the unnecessary postulate of “wave-particle duality”.*